

AWS[®] 100

The Bench Top
Analyzer Water System.

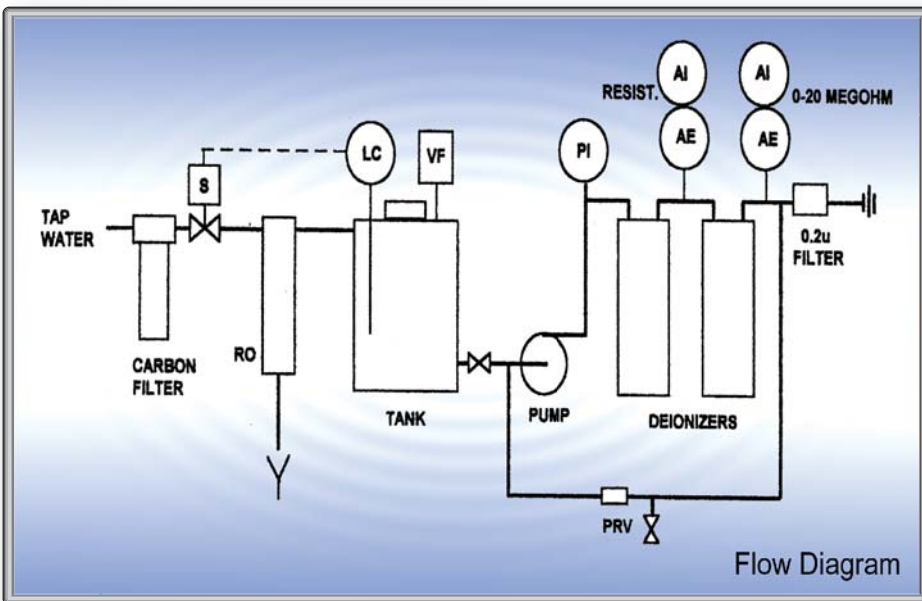

Laboratory Uses:

CAP, ASTM Type I, and NCCLS Type I reagent grade water for clinical analyzers

Performance

- 10 megohm-cm resistivity
- Less than 0.05 mg/L silicate
- Less than 10 CFU/mL bacteria
- Less than 0.2 micron particles
- Organics removed via activated carbon treatment
- 1.0 liter per minute peak flow rate
- 15 liter tank capacity

Description

- Dimensions: 25H" X 21W" X 15D"
- Power: 120V/60 Hz (25 VA)
- Organic Adsorption: chlorine removal
- Reverse Osmosis: ionic, organic, bacterial, and pyrogenic reduction
- Ion Exchange: total ionic removal
- Recirculating pump maintains water purity
- Reservoir accommodates peak demand

Easy Maintenance

Hydro provides a service agreement schedule that makes replacing expendables quick and easy. All parts are clearly labeled and correlate to a service diagram found on the access panel. Hydro provides an AWS support team to assist you with any questions.



A24-8/04

Service and Supplies

CORPORATE OFFICES:

PO BOX 12197, Research Triangle Park, NC 27709

800.950.7426

www.hydroservice.com

DIVISION OFFICES:

Raleigh/Durham, NC
Rockville, MD
Pennsylvania

919.361.5188
301.770.2120
215.547.0332

New Jersey
Massachusetts
Connecticut

973.926.0203
781.337.1203
203.265.3995